

**Kalkhoff - E-Bikes 2011**

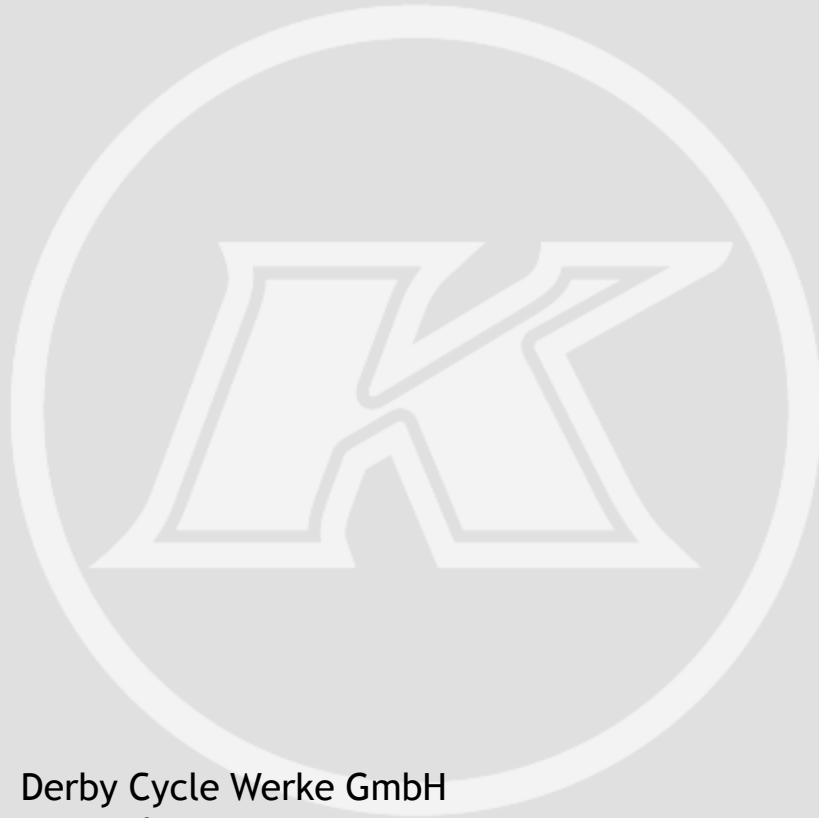

Derby Cycle Werke GmbH  
Karl- Heinz Lange  
Christian Bittar  
Rainer Brinkmann



1. **Legal requirements**
2. **What is new in 2011**
3. **E-Bike Basics**
  - **Parts of the Center Motor**
  - **Performance curves**
4. **Battery technology**
  - **Technology**
  - **Lifetime**
  - **Efficiency**
5. **Front hub motor**
6. **Rear hub motor**

## What is a Pedelec?

### EU-Directive 2002/24/EC

- ✓ max. assist power output of the Motors is 250 W
- ✓ The motor may only be used to support pedalling, i.e. it is only permitted to “help” when the rider is pressing on the pedals..
- ✓ The assist power must decrease in a progressive way upon speed increase.
- ✓ The assist power must stop completely at 25 km/h. (+ Tolerance)

**Legally, the Pedelec falls under the machinery Directive 2006/42/EC**

## What is the result of this?

- ✓ **Pedelecs must meet the EMC Directive**
- ✓ **Legal risk reduction:**
  - a) **Additional information in manual**  
for example: definition of the operational area etc.
  - a) **protocol at the sale in stores**
- ✓ **CE marking / CE declaration of conformity in manual**

## Which effect has this for the consumer?

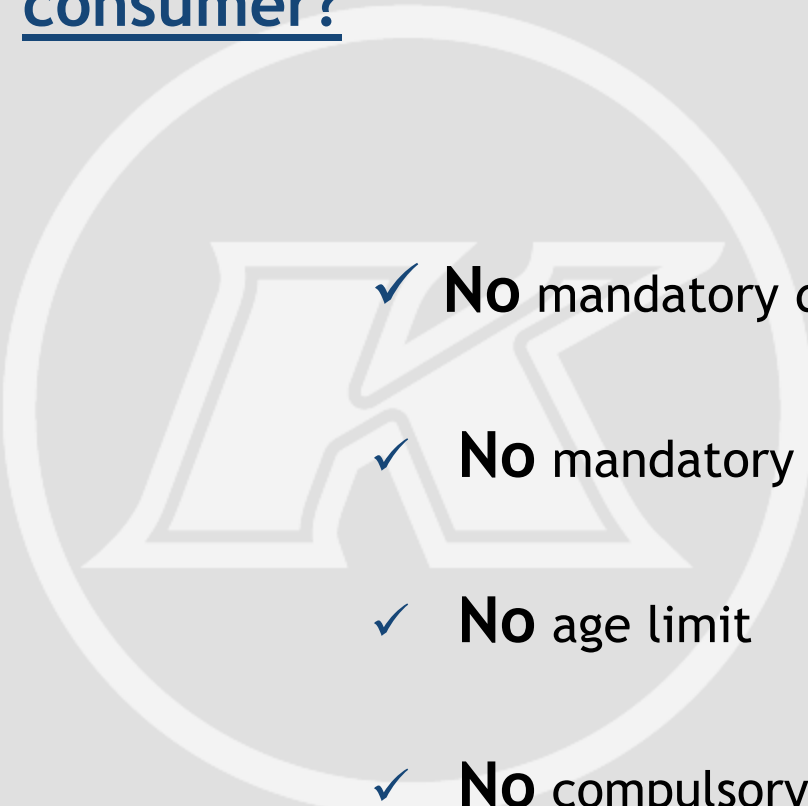
- 
- ✓ **No** mandatory driving licence
  - ✓ **No** mandatory wearing of a helmet
  - ✓ **No** age limit
  - ✓ **No** compulsory insurance

## What is a e-bike or a speed pedelec?

- ✓ It is a motorcycle.
- ✓ Two categories: up to 500 Watt / from 500 to 1000 Watt (In case of more than 500 Watt motorcycle lighting und wheels required).
- ✓ "DD-throttle"/"DD-button" required
- ✓ Max. 20 km/h with E-Motor power (mandatory wearing of a helmet).

**Please check the law in your country! It could be different.**

## Which effect has this for the consumer?

- 
- ✓ You need a driving licence
  - ✓ You must be 15 years old
  - ✓ You need no helmet (because of the max. motor speed)
  - ✓ You need an insurance

**Please check the law in your country! It could be different.**

## Different driving units



Center motor



Front hub motor



Rear hub motor



- 
1. Legal requirements
  2. **What is new in 2011**
  3. E-Bike Basics
  4. Battery technology
  5. Front motor unit
  6. Rear motor unit

## What is new for 2011

### All Panasonic Pedelecs:

- new battery technologie
- new battery capacities 8Ah / 12Ah / 18Ah
- same key for lock and battery lock
- new charger with 4A charging current from February



## What is new for 2011

### Speed pedelec:

- Assistance 1:2 / 1:1,3/ 1:0,75
- LCD display
  - change modus in two directions
- assistance up to higher speed
- new rear mirror
- optimized performance curve
- adapted cadence

### Pedelec center motor:

- Assistance 1:2 / 1:1 / 1:0,5 for all models
- optimized performance curve
- new chain tensioner
- new LED display
  - new design with back light
  - change modus in two directions

### Pedelec front hub motor

- Assistance 1:2 / 1:1 / 1:0,5 for all
- optimized performance curve
- new LED display
  - new design with back light
  - change modus in two directions

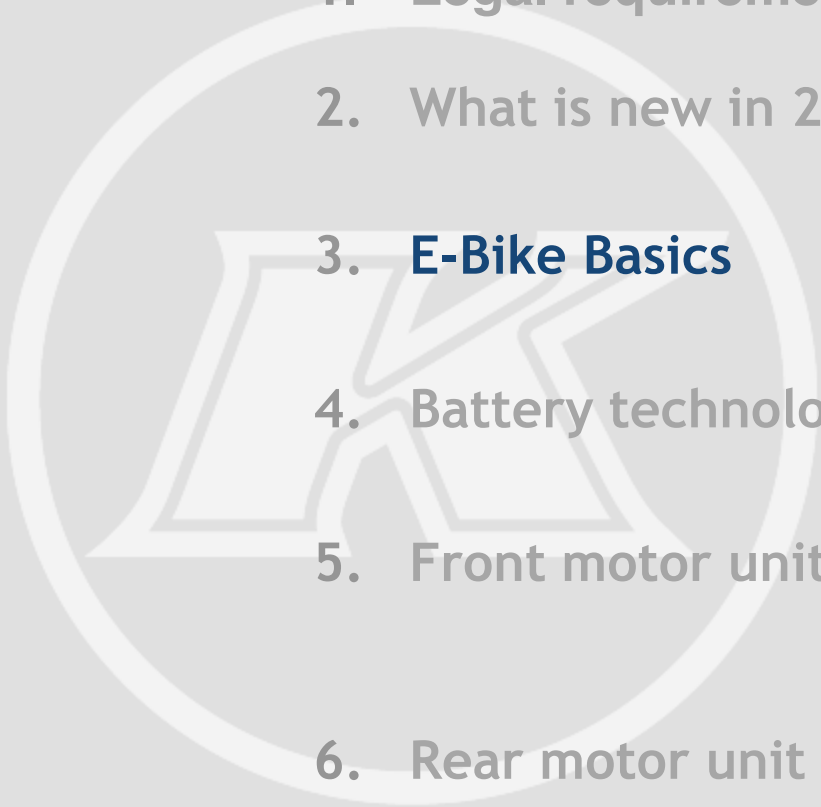
- 
1. Legal requirements
  2. What is new in 2011
  3. **E-Bike Basics**
  4. Battery technology
  5. Front motor unit
  6. Rear motor unit

## E-Bike technology - motor unit and drive

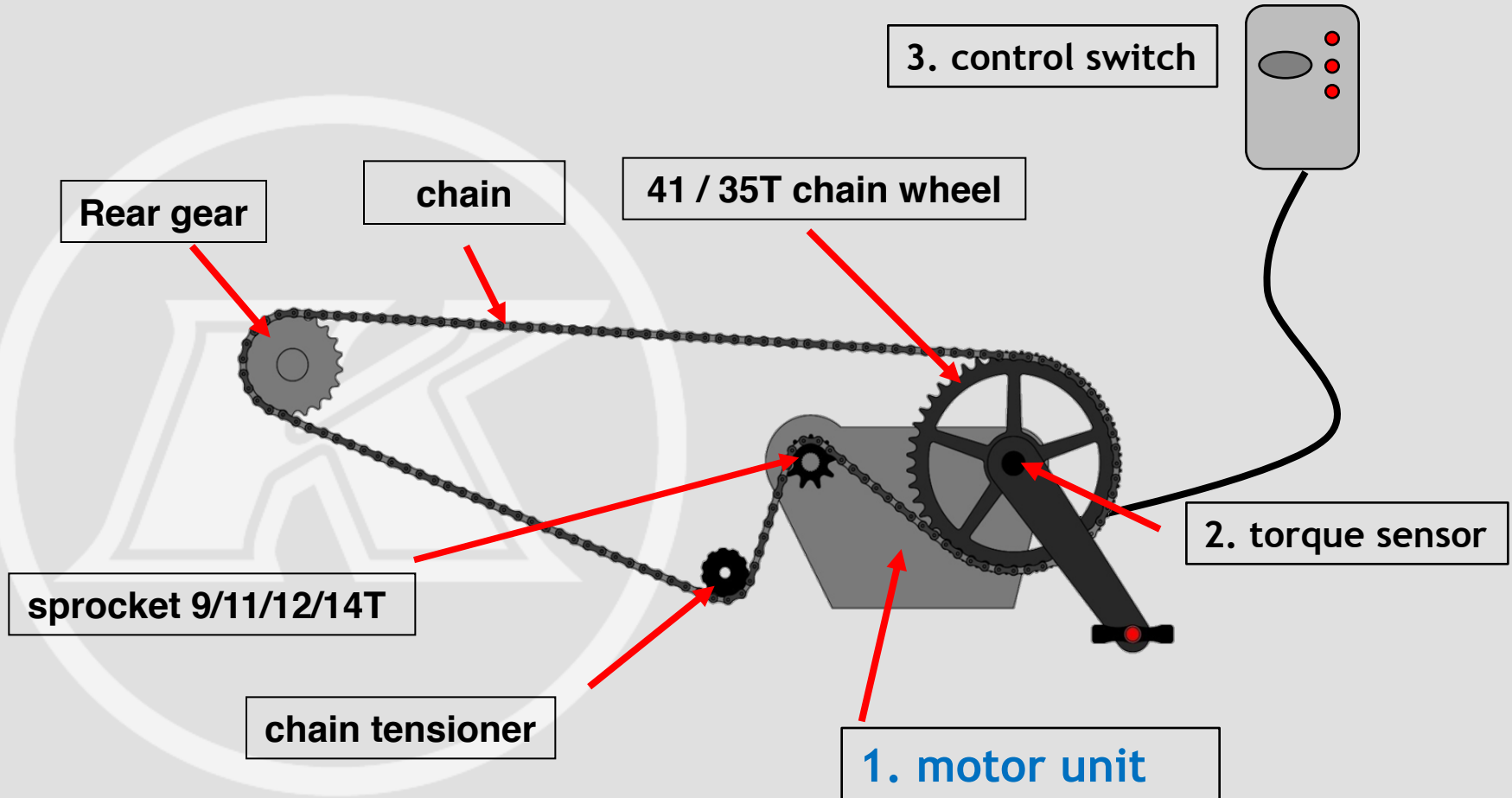

## Driving unit and control system

- 3 in 1 construction (engine, controller & torque sensor)  
very short electromagnetic loading
- Weight of the drive unit: 3.8 kgs

### Component parts:

- Brushless motor
- Controller
- Gear unit (transmission)
- Chain tensioner
- control switch
- Torque sensor

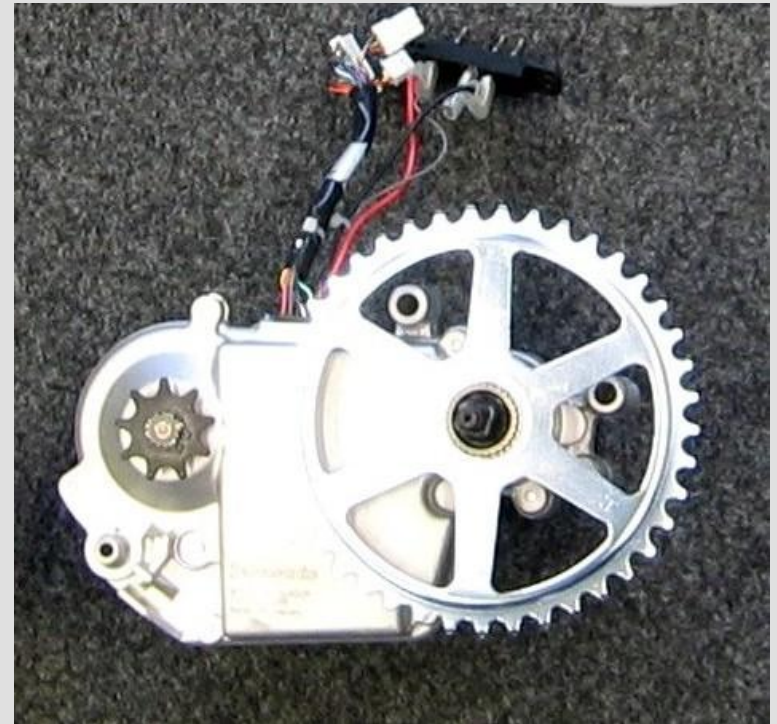

## E-Bike technology - motor unit and drive

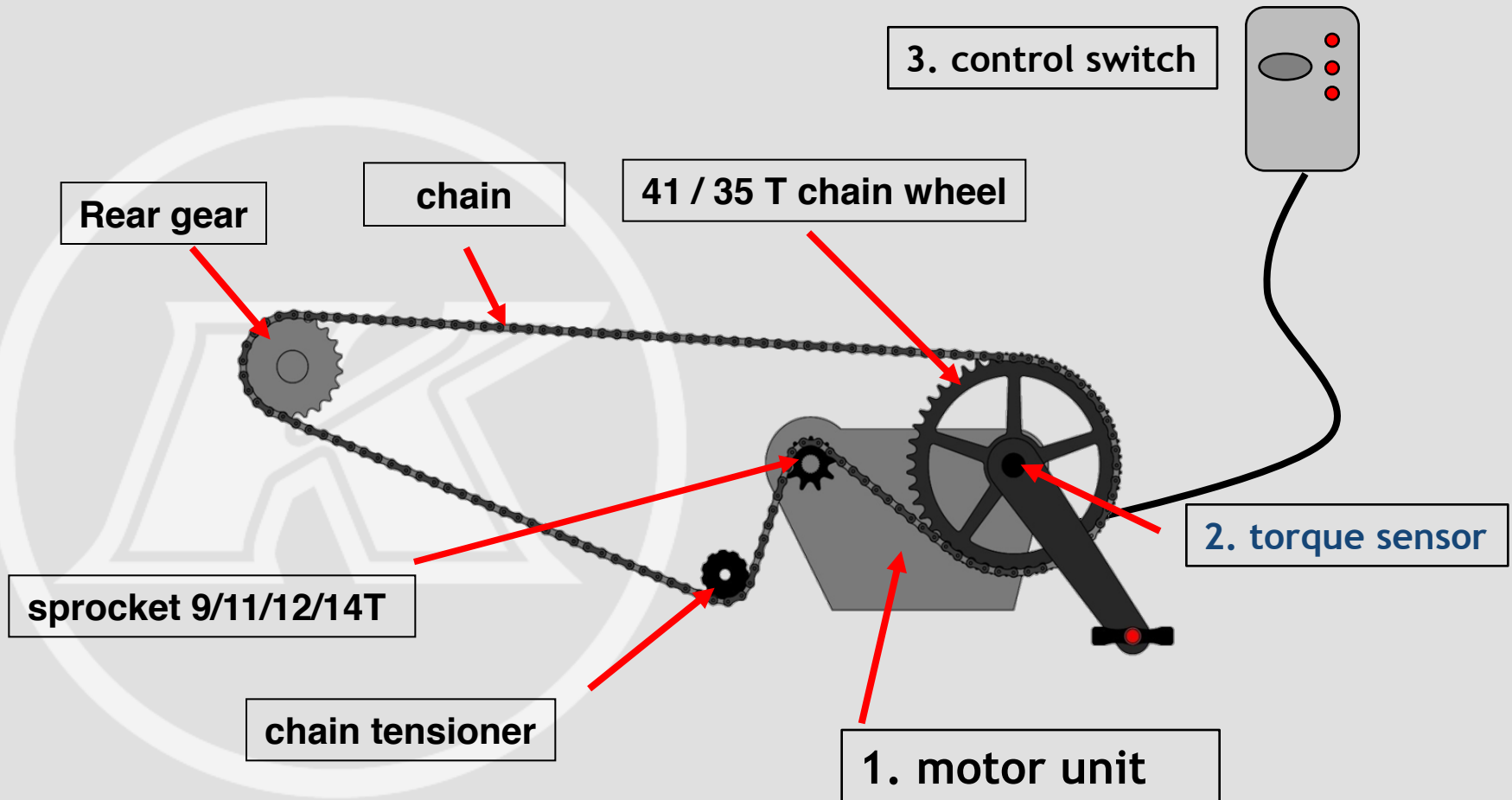

## Non-contact magnetic torque sensor

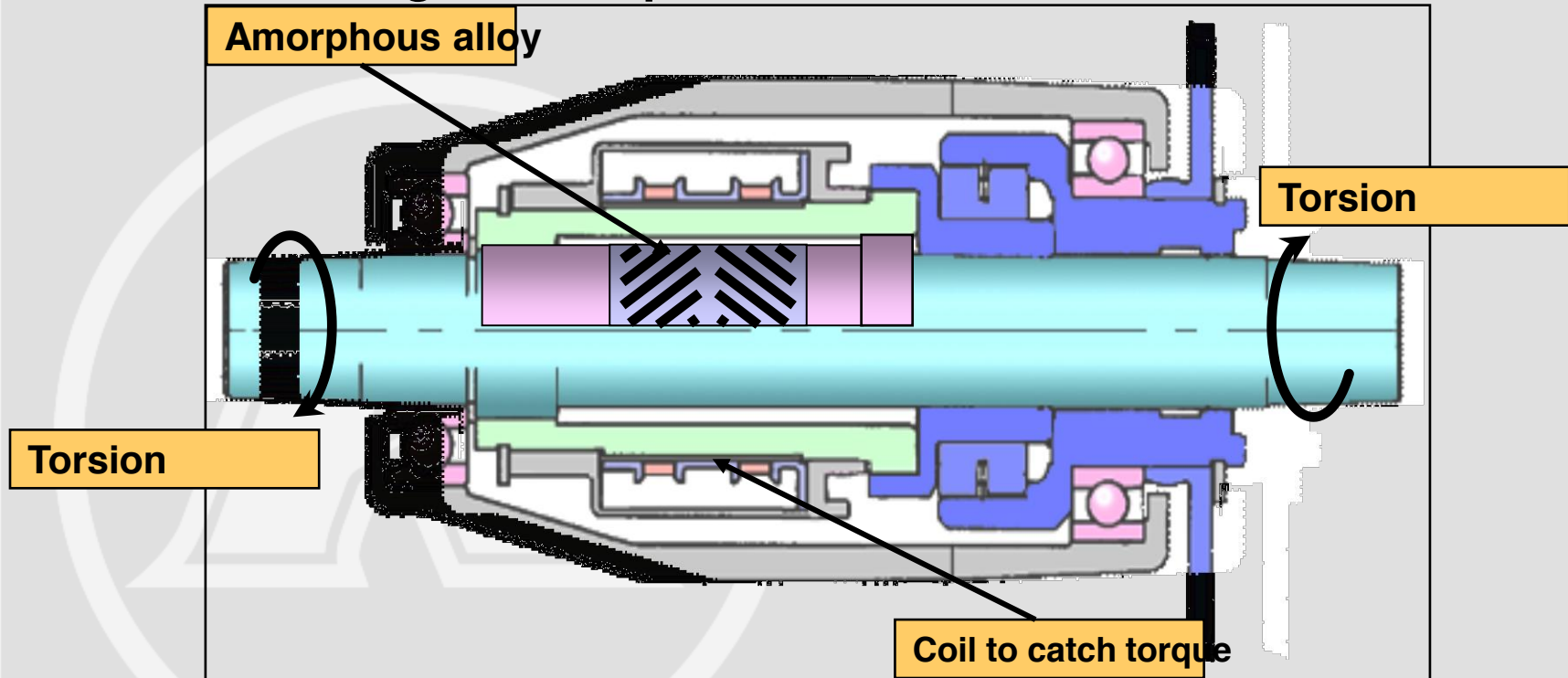

- Feature for non-contact magnetic torque sensor
- No loss for transmission
- Still easy pedalling after power off or battery used up
- Worldwide patent (quick and accurate response to pedal torque)



## E-Bike technology - motor unit and drive

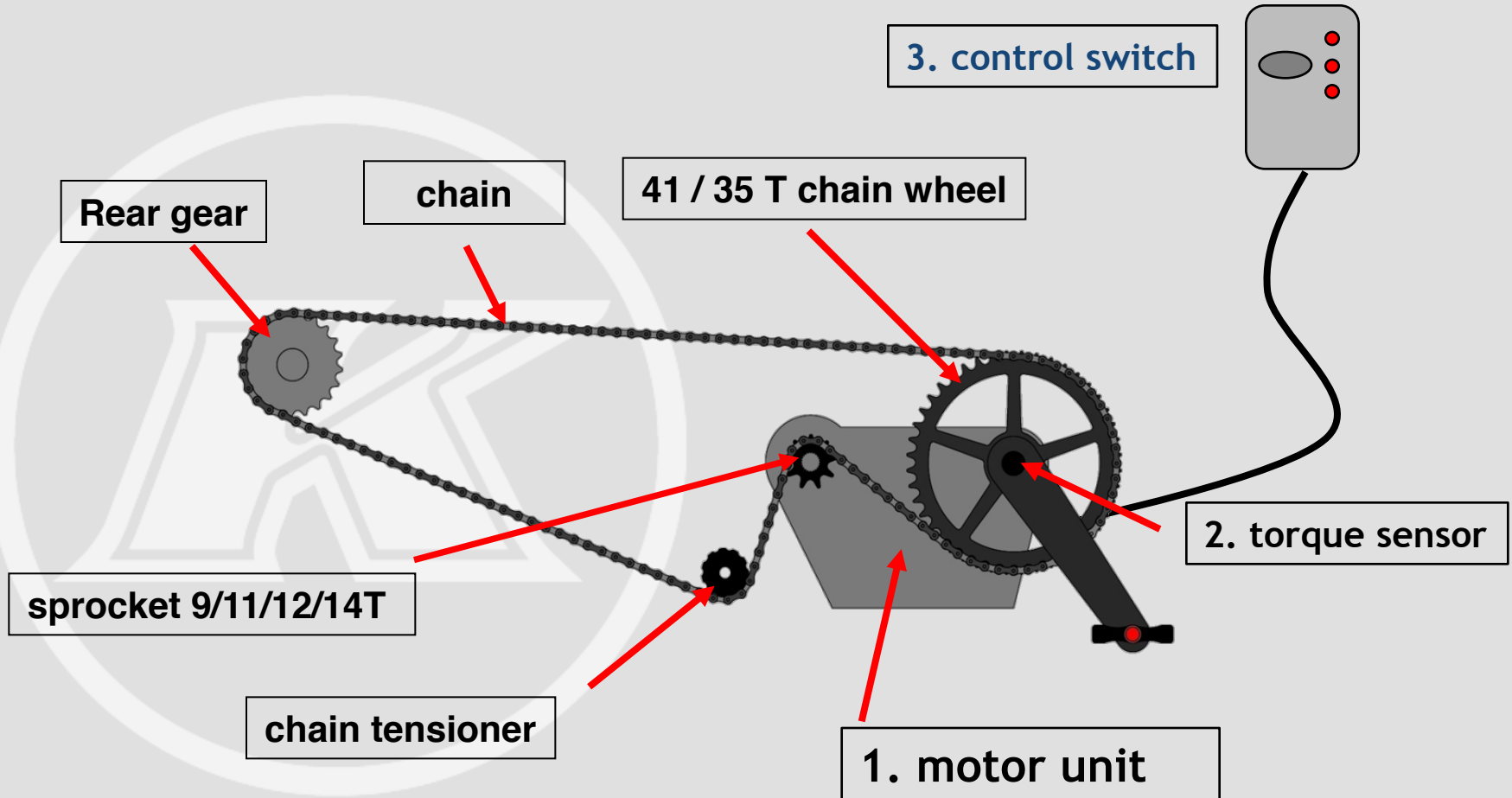

## E-Bike technology - LED control switch

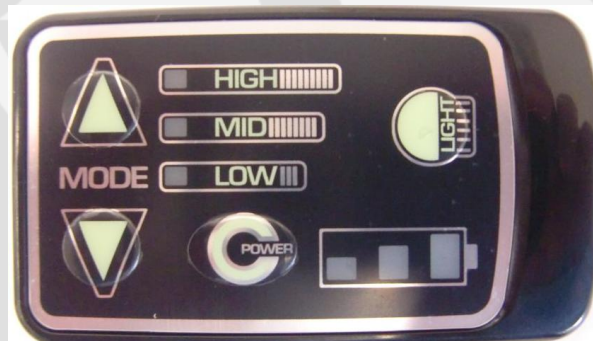

### Battery capacity

- 100%-70% (3 LED shining)
- 70% - 40% (2 LED shining)
- 40% - 10% (1 LED shining)
- under 10% (last LED blinking)

### Assist mode

change modus in two directions

- 1:2 (high)
- 1:1 (medium)
- 1:0,5 (eco)

When you switch it on, the assist mode is the same as when you switch it off

With back light

## E-Bike technology - LCD control switch





- standard function cyclometer
- 10 languages selectable
- Assist mode (1:2 / 1:1,3 / 1:0,7)
- change modus in two directions
- backlight
- Power indicator 6 steps
- Battery capacity

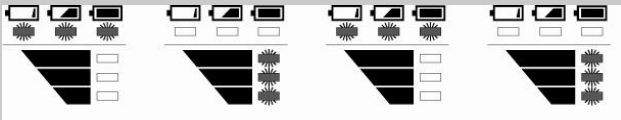

5 elements	80 - 100%
4 elements	60 - 80%
3 elements	40 - 60%
2 elements	20 - 40%
1 element	10 - 20%
blinking	Capacity under 10%.

When you switch it on, the assist mode is the same as when you switch it off

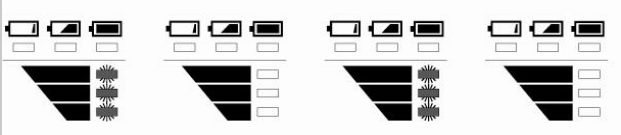
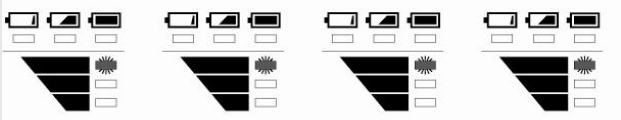
## E-Bike Technology - Self-fault-diagnosis system LED

Errorcode	Error	Solution
	No electric assistance. The torque sensor was unable to reset itself correctly.	Restart the system. The system will be calibrated again; during which time no pressure must be exerted on pedals.
	No electric assistance. Motor defect	Motor must be replaced - please contact your specialist dealer
	The motor has cut out - the motor is overloaded	Allow the motor to cool and reduce the level of assistance
	The motor has cut out - the motor is extremely overloaded	Allow the motor to cool and reduce the level of assistance
	No electric assistance. The battery is almost empty	Charge the battery as soon as possible

**E-Bike Technology -  
Self-fault-diagnosis system LCD**

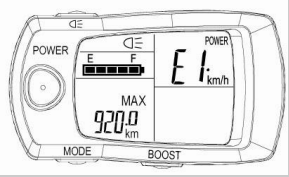
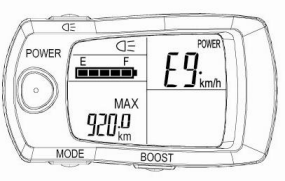
<b>Errorcode</b>	<b>Error</b>	<b>Solution</b>
 <p>The image shows a close-up of the LCD display. The top left corner shows 'POWER' and 'E F' with a battery level indicator. The top right corner shows 'POWER' and 'E1 km/h'. The bottom left corner shows 'MAX 920.0 km' and 'MODE'. The bottom right corner shows 'BOOST'.</p>	<p>You may have pressed down on the pedals shortly after pressing the “Power” button. - wrong calibration</p>	<p>Turn the display off. Now turn it back on and wait for around 2 seconds before starting to pedal</p>
 <p>The image shows a close-up of the LCD display. The top left corner shows 'POWER' and 'E F' with a battery level indicator. The top right corner shows 'POWER' and 'E9 km/h'. The bottom left corner shows 'MAX 920.0 km' and 'MODE'. The bottom right corner shows 'BOOST'.</p>	<p>A problem has occurred in the drive unit - no motor assistance</p>	<p>Motor defect - please contact your specialist dealer</p>
<p>The display shows sufficient battery charge but the assistance control display is flashing</p>	<p>The drive unit has been overloaded and the battery management system has been activated . As a result, the amount of assistance that can be delivered is limited</p>	<p>After a brief pause for the drive to recover, you will once again be able to use full electric assistance. If this is not the case, please contact your specialist dealer</p>

## E-Bike Technologie - performance curve

Characteristic of the motor unit with rising speed

2. pedelec: 28" - 8 speed shimano

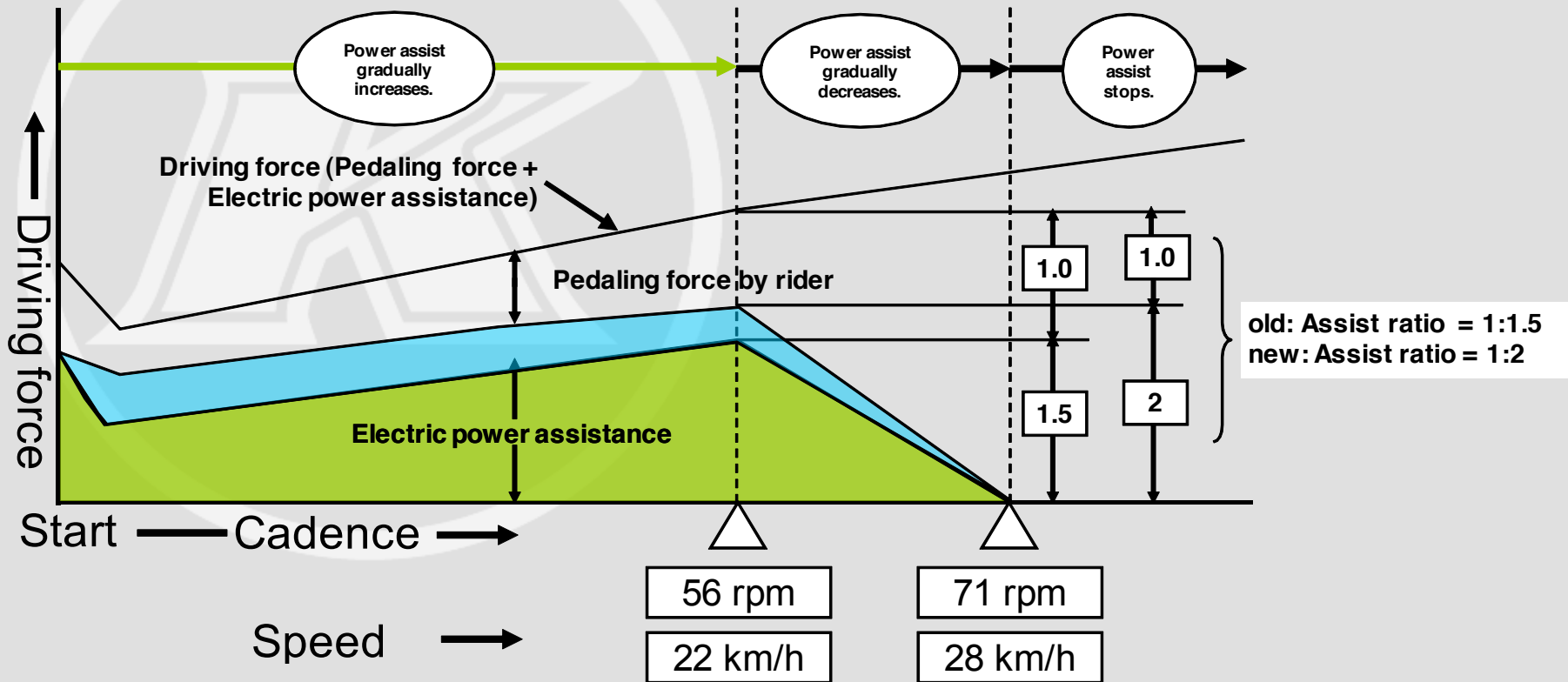

## E-Bike Technologie - performance curve

Characteristic of the motor unit with rising speed

4. speed pedelec - 28"

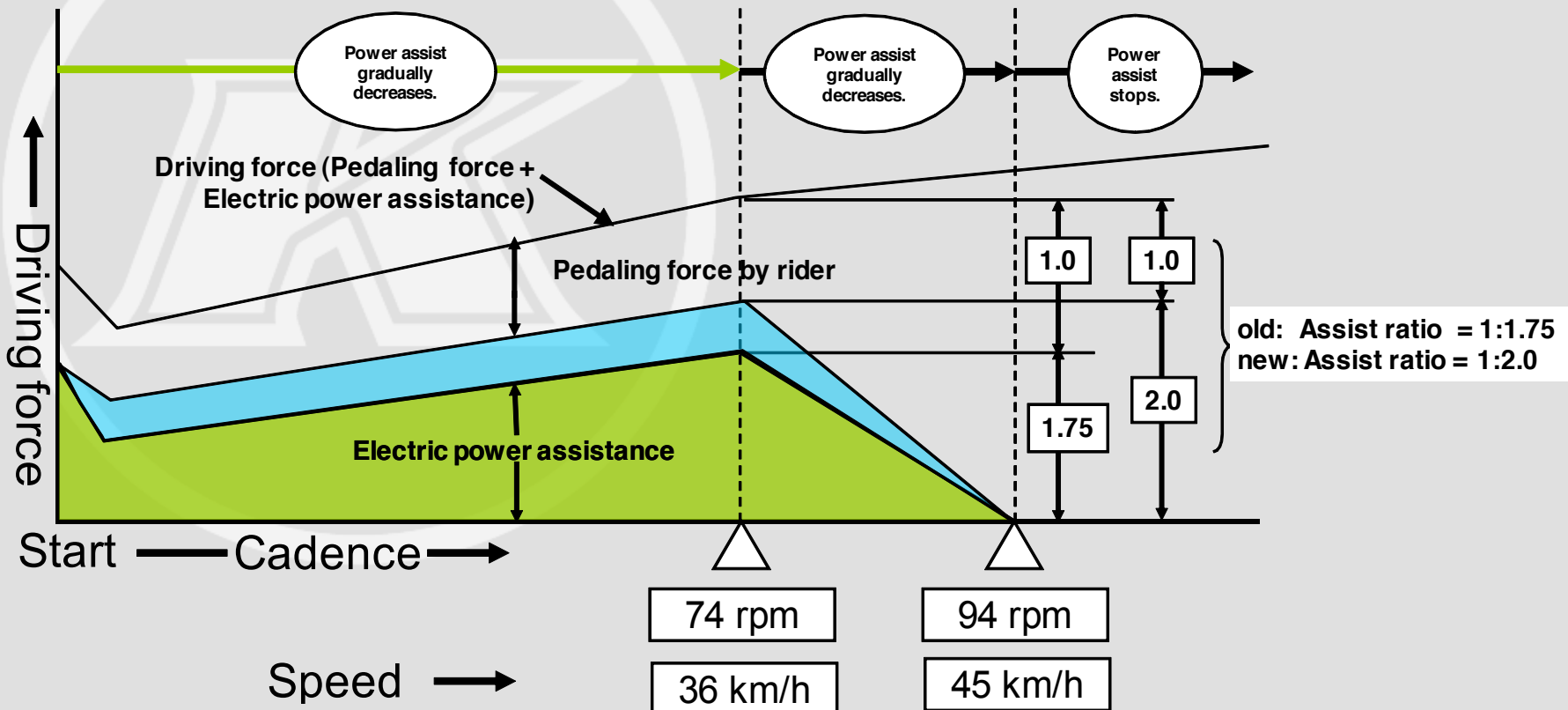

1. Legal requirements
2. What is new in 2011
3. E-Bike Basics
4. **Battery technology**
5. Front motor unit
6. Rear motor unit



## E-Bike technology - Battery technology

### Li- Ion- Cobalt battery Cell:

3,6 V (50% charge)  
 4,2 V (complete charged)  
 3 V (discharged (2,5V))

2,25 Ah

18 Ah batterie contains 56 cells  
 7 cells in series a'3,6V x 7 = 25,2V  
 8 cells parallel a'2,25 Ah x 8 =18 Ah

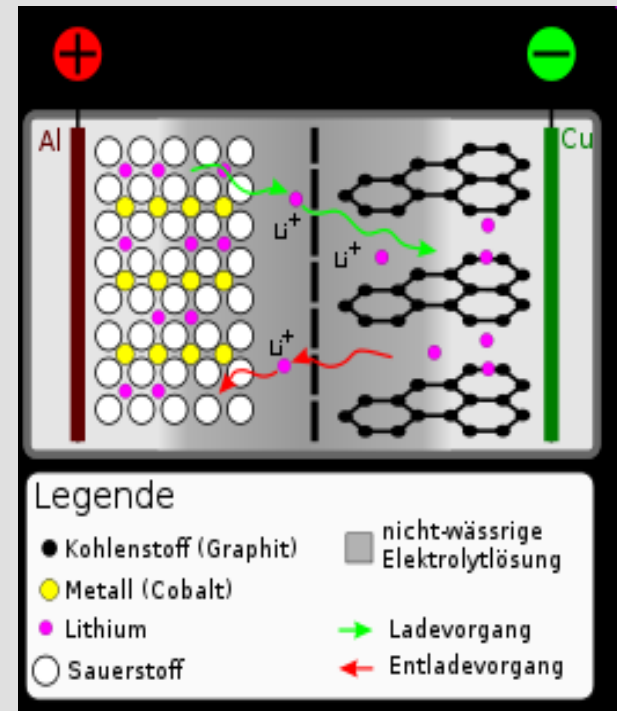
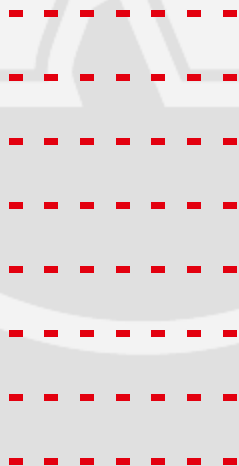

## E-Bike technology - Battery technology

### technical data:

	8 Ah	12 Ah	18 Ah
Voltage	25,2 V	25,2 V	25,2 V
Capacity	8 Ah	12 Ah	18 Ah
Watt hours	200 Wh	300 Wh	450 Wh
Weight	1,9 kg	2.6 kg	3,1 kg
Lifetime	1100 cycles of charge	1100 cycles of charge	1100 cycles of charge
Driver line	Pedelec 60 km Speed 29 km	Pedelec 90 km Speed 35 km	Pedelec 140 km Speed 60 km
Costs	449 Euro		599 Euro



## E-Bike technology - Advantages of the Li-Ion battery

### Simple charging:

- ✓ no memory effect
- ✓ no refresh loadings necessary
- ✓ recharge after 6 months necessary

### High security:

- ✓ against short-circuit
- ✓ overloading
- ✓ impact

### Simple store:

- ✓ at approx. 3/4 state of charge and approx. 10°C  
(if you don't use the battery for a long time)
- ✓ sleep mode: at 50% of the capacity after 2 weeks;  
or  
after 4 months without using

### What is necessary for a long lifetime?

- ✓ No depth discharge → Try not to ride the Pedelec till the battery is complete empty
- ✓ charging in the correct temperature range → not over 35°C
- ✓ correct store → approx. 50-70% of the capacity, cool store

**This advantages of the Panasonic battery are possible because of an intelligent battery managemant!**

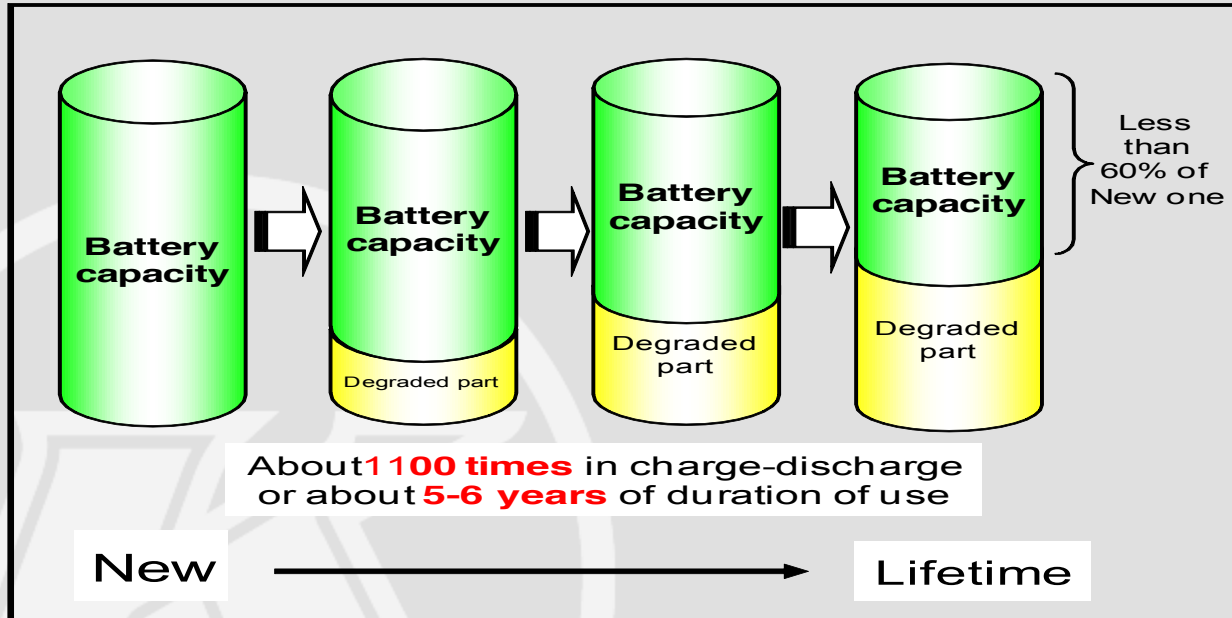

## What does it mean: the complete capacity during lifetime of the battery?

- ✓ After the complete use of 15840Ah the battery has rest capacity of min. 10,8Ah
- ✓ That means average  $1100 \times 14,4 \text{ Ah} = 15840\text{Ah}$

Capacity	Complete use	60 % limit
8 Ah	7040 Ah	4,8 Ah
12 Ah	10560 Ah	7,2 Ah
18 Ah	15840 Ah	10,8 Ah

## Which parameters influence the operating distance?

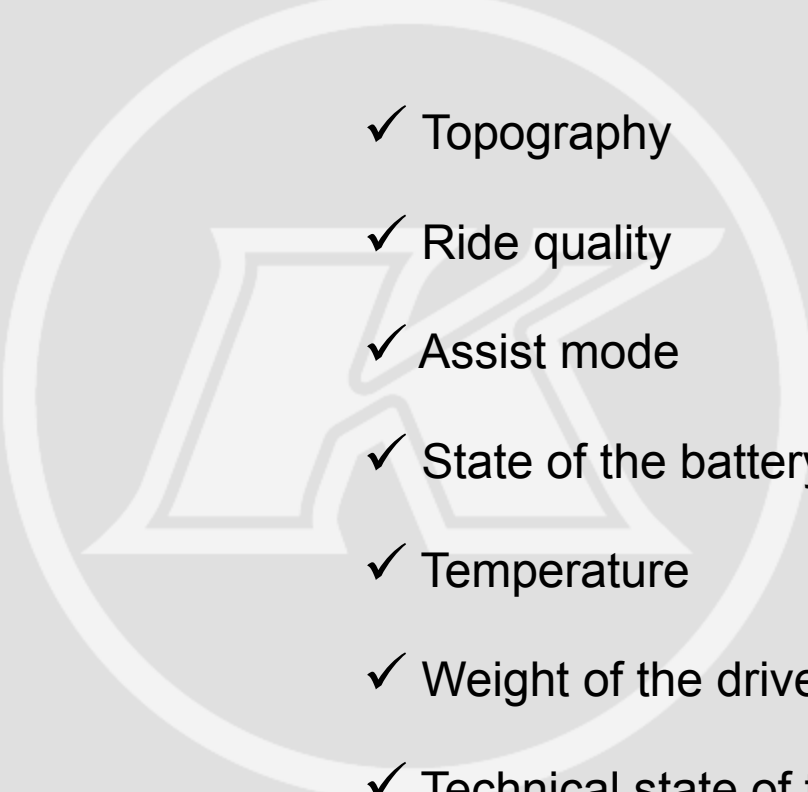
- 
- ✓ Topography
  - ✓ Ride quality
  - ✓ Assist mode
  - ✓ State of the battery
  - ✓ Temperature
  - ✓ Weight of the driver
  - ✓ Technical state of the bike

## E-Bike test ride - Driver line

	Pedelec			Speed Pedelec		
	8 Ah	12 Ah	18 Ah	8 Ah	12 Ah	18 Ah
<b><u>Drive line</u></b>	<b><u>60 km</u></b>	<b><u>90 km</u></b>	<b><u>140 km</u></b>	<b><u>22 km</u></b>	<b><u>35 km</u></b>	<b><u>60 km</u></b>
<b>Test specifications:</b>						
temperature	12-17 C					
Wind speed	windstill					
Ø speed	22 km/h			32 km/h		
Assist mode	1:1			1:2		
Weight of driver + payload + Pedelec	105 - 110 kg					

**E-Bike advantages - Efficiency**

	<b>10 Ah</b>	<b>8 Ah</b>	<b>18 Ah</b>
Charge circles	500	1100	1100
Drive line	80 km	60 km	140 km
Drive line complete	40000 km	66000 km	154000 km
Costs of the battery	500 €	449 €	599 €
Costs per km	1,3 Cent/km	0,68 Cent/km	0,39 Cent/km
Power output during on charge	341 Wh	275 Wh	620 Wh
Costs for on charge with 20 Cent/kWh	6,82 Cent	5,5 Cent	12,4 Cent
Charging cost per km	0,09 Cent/km	0,09 Cent/km	0,09 Cent/km

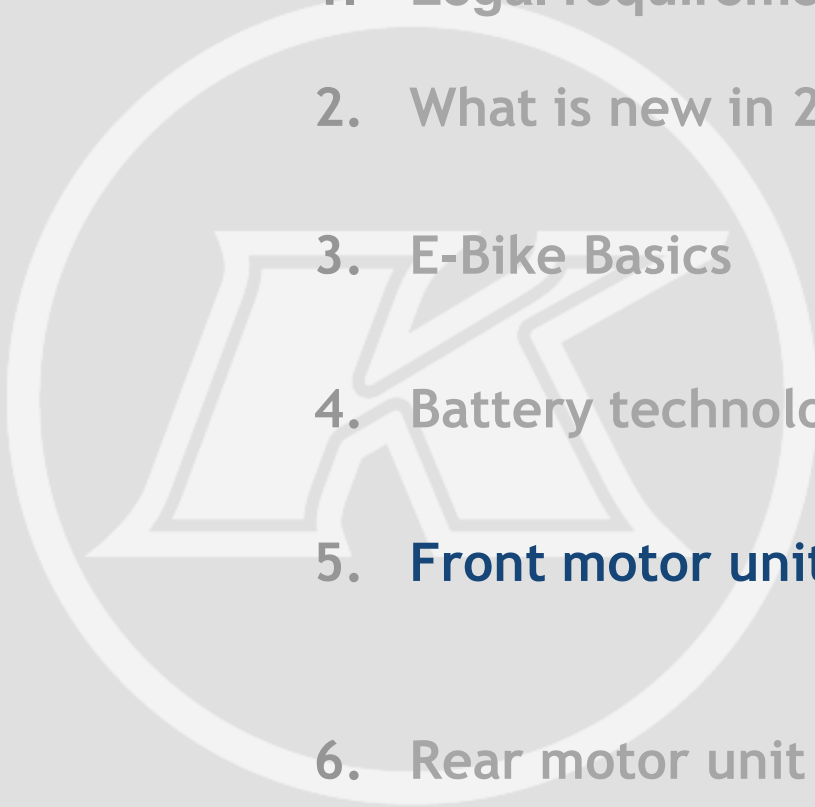
- 
1. Legal requirements
  2. What is new in 2011
  3. E-Bike Basics
  4. Battery technology
  5. **Front motor unit**
  6. Rear motor unit



## E-Bike technology Front hub motor

- ✓ compatible with standard wheel fork dimension 100 mm
- ✓ weight 2.2 kgs (this is currently the lightest front wheel drive)
- ✓ compact architecture diameter 132 mm
- ✓ brushless driving motor at a high efficiency (84 %)
- ✓ power 250 Watt
- ✓ voltage 26 Volt direct current
- ✓ Hub motor with dynamo function without freewheel

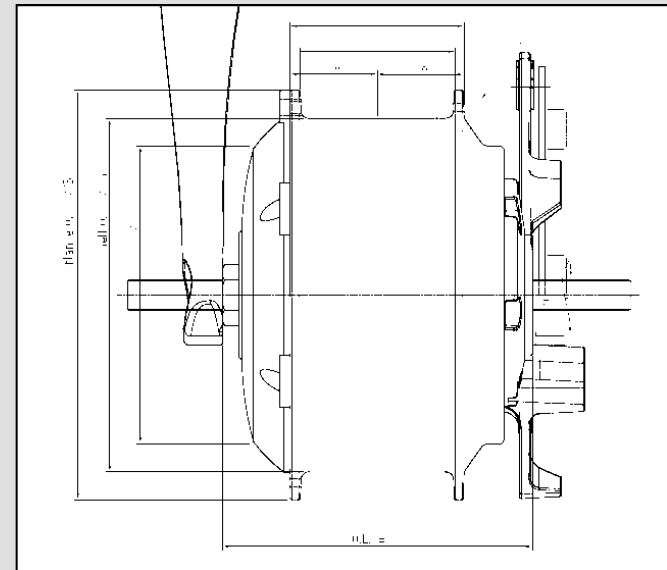

## E-Bike technology - Front hub motor

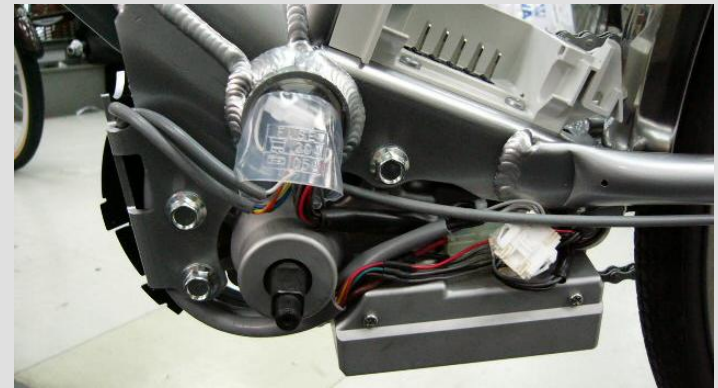

amorphe metal chuck

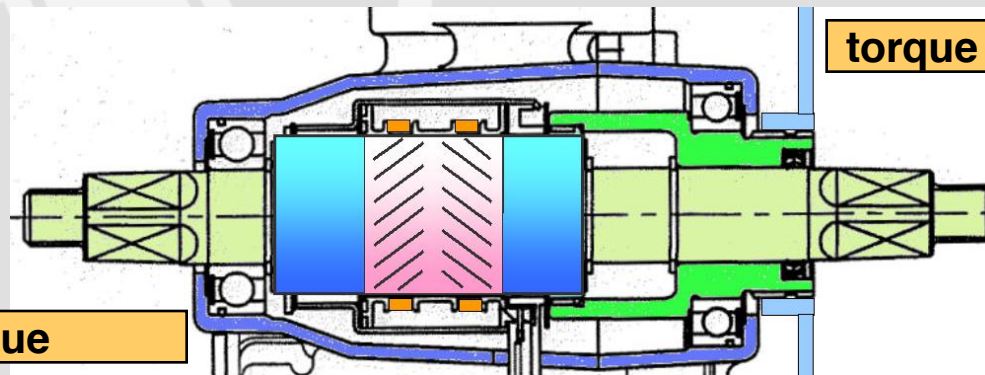

torque

torque

coil back to torque snapshot

**E-Bike technology - Inside permanent magnets**



**IPM rotor**

**magnet**

The stator is infused in resin

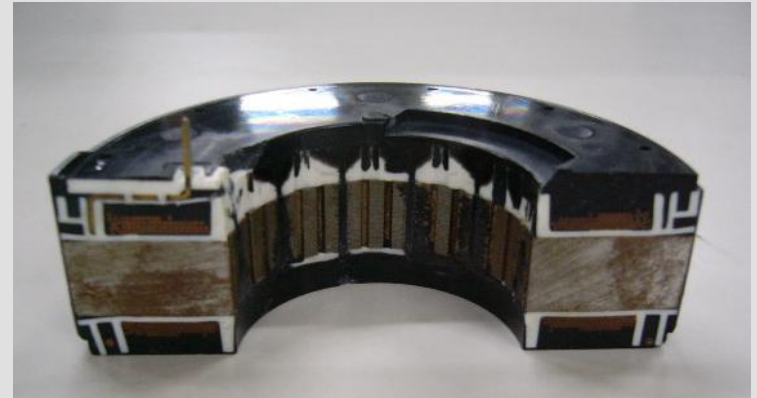
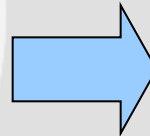

**E-Bike technology - Gear unit**

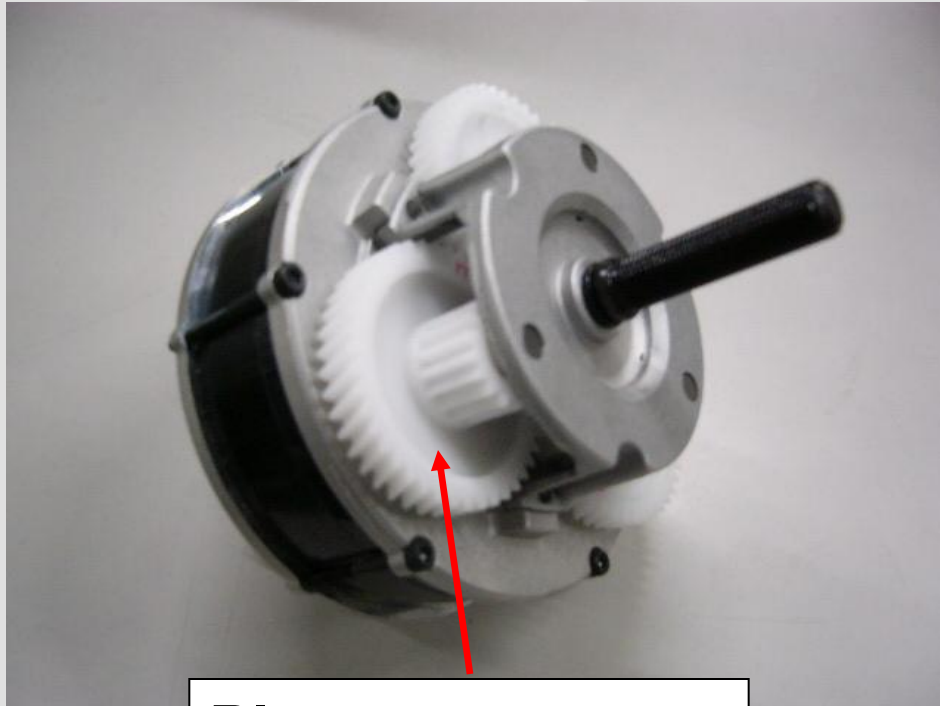

**Planet gear**

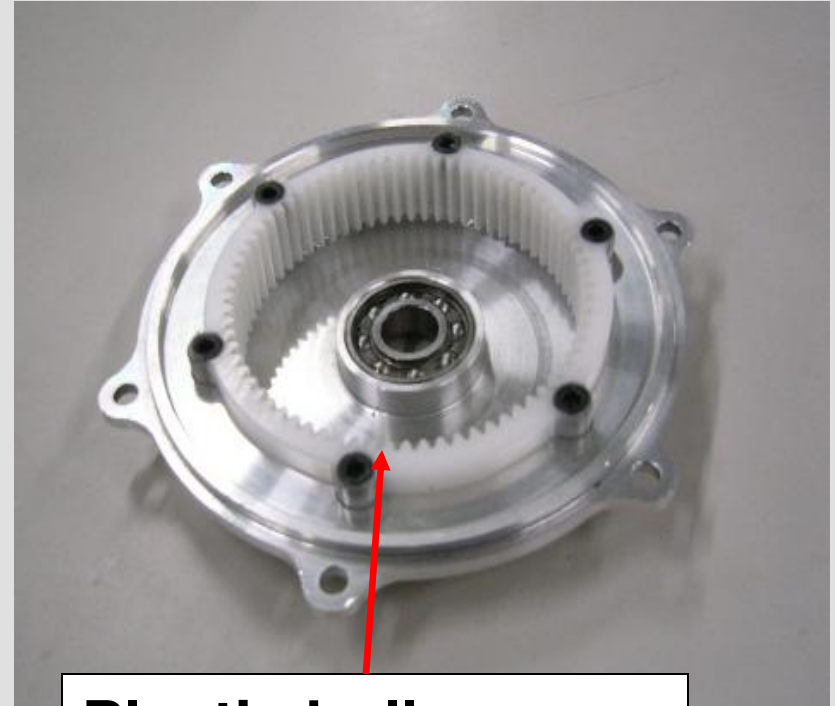

**Plastic hollow gear**

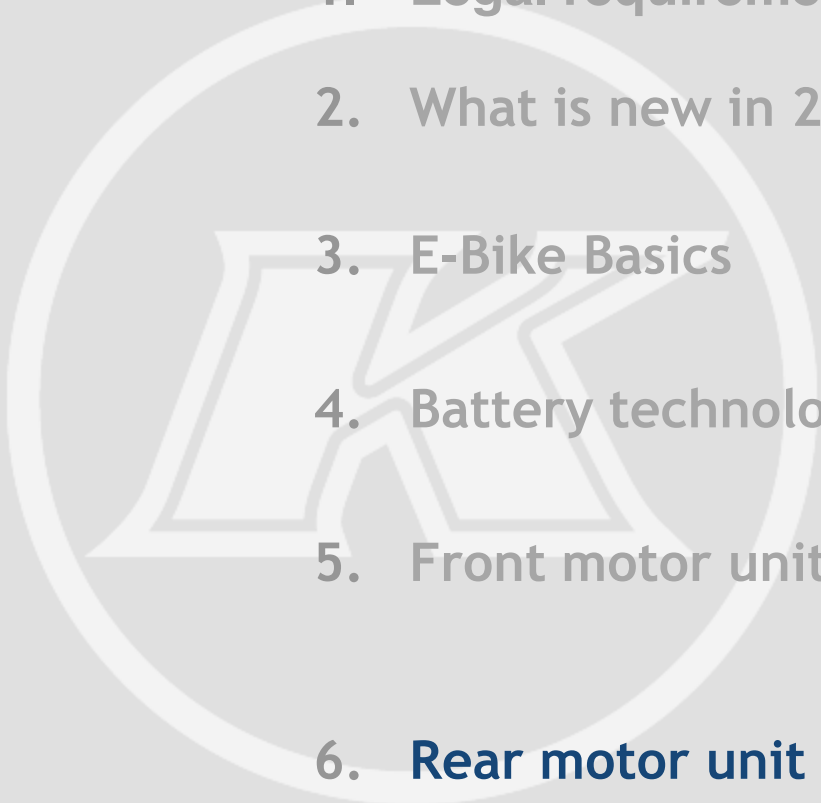
- 
1. Legal requirements
  2. What is new in 2011
  3. E-Bike Basics
  4. Battery technology
  5. Front motor unit
  6. **Rear motor unit**

## Heckantrieb - BionX - models



Focus Jarifa Offroad



Image B27 BionX

## Rear Hub Drive - BionX - NEW for 2011

- Rear Hub Unit: 250 Watt HT (High Torque)
- Power: 250 Watt
- Torque: 9 Nm (steady) / 35 Nm (peak)
- Battery: Li-Ion 37V / 9Ah - 325Wh
- Distance in middle Assist Mode: 70Km +/-
- Assist Mode: 1:0,35 / 1:0,75 / 1:1,5 / 1:3
- Charging Time: around 3h
- Weight of Battery: 2400g (calculated)
- Display: New Bionx G2 Console
- Energy recuperation: 4 Steps to 15% for manual choice  
works like an engine brake
- Delivery BionX Systems / Assembling: from March 2011



**There is only one E-Bike fact left:  
Only a short test-ride will convince  
everyone**

**Thank you for your attention  
Time for questions**

Derby Cycle Werke GmbH  
Karl- Heinz Lange  
Christian Bittar  
Rainer Brinkmann